

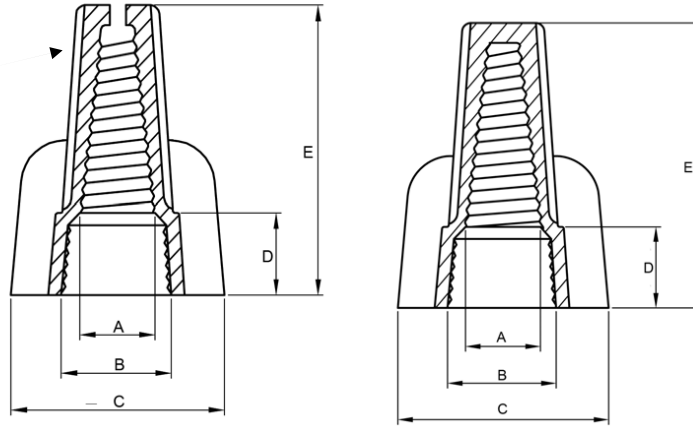

**AL-ACG-GN
(Model #: P99)



| ADVANCED CABLE TIES PART NUMBER | WIRE RANGE | A IN (mm) + / - .007 (0.2 mm) | B IN (mm) + / - .007 (0.2 mm) | C IN (mm) + / - .007 (0.2 mm) | D IN (mm) + / - .007 (0.2 mm) | E IN (mm) + / - .007 (0.2 mm) | COLOR | VOLTAGE | ANSI/UL 94 MH FLAMABILITY RATING | WORKING TEMPERATURE | REGULATORY APPROVALS |
|---|--|--|--|--|--|--|--|----------|--|------------------------|-------------------------|
| AL-ACW-YW (Model #: P11V) | #18-#10 AWG MAX: 2#12 W/1#14 MIN: 3#18 | .251 (6.40mm) | .385 (9.80mm) | .716 (18.20mm) | .354 (9.00mm) | 1.015 (25.80mm) | YELLOW | 600V MAX | V-2 | 105°C | UL& CSA |
| AL-ACW-TN (Model #: P12) | #22-#8 AWG MAX: 4#12 MIN: 3#22 SOL | .283 (7.20mm) | .437 (11.10mm) | .720 (18.30mm) | .362 (9.20mm) | 1.141 (29.00mm) | TAN | 600V MAX | V-2 | 105°C | UL& CSA |
| AL-ACW-RD (Model #: P13) | #18-#8 AWG MAX: 5#12 SOL MIN: 3#16 | .354 (9.00mm) | .511 (13.00mm) | .905 (23.00mm) | .377 (9.60mm) | 1.251 (31.80mm) | RED | 600V MAX | V-2 | 105°C | UL& CSA |
| AL-ACW-GY (Model #: P15) | #18-#8 AWG MAX: 3#10 MIN: 3#14 W/1#18 | .393 (10.0mm) | .586 (14.90mm) | 1.003 (25.50mm) | .393 (10.00mm) | 1.311 (33.30mm) | GREY | 600V MAX | V-2 | 105°C | UL& CSA |
| AL-ACW-BL (Model #: P17) | #14-#6 AWG MAX: 3#8 W/1#12 MIN: 2#10 W/1#12 | .472 (12.00mm) | .700 (17.80mm) | 1.259 (32.00mm) | .511 (13.00mm) | 1.574 (40.00mm) | BLUE | 600V MAX | V-2 | 105°C | UL& CSA |
| **AL-ACG-GN (Model #: P99) | #14-#10 AWG MAX: 5#12 MIN: 2 #14 | .326 (8.30mm) | .464 (11.80mm) | .795 (20.20mm) | .370 (9.40mm) | 1.133 (28.80mm) | GREEN | N/A | V-2 | 105°C | UL& CSA |
|  | | | | | | | ADVANCED CABLE TIES – WING STYLE SCREW-ON WIRE CONNECTORS | | | | |
| | | | | | | | STEEL | | TOUGH THERMOPLASTIC | | |
| | | | | | | | SHEET 1 OF 1 | REV.: A | DRAWING NO.: WING-A | | |
| A | 4/11/14 | JA | KT | KT | INITIAL RELEASE | | DRAWN BY | DATE | CHECK | SCALE | |
| REV | DATE | BY | CHK | APPROVE | DESCRIPTION | | JA | 4/11/14 | KT | NONE | |
| CONFIDENTIAL PROPERTY OF ADVANCED CABLE TIES, INC. THIS DRAWING IS PROVIDED ON A RESTRICTED BASIS AND IS NOT TO BE USED IN ANY WAY DETRIMENTAL TO THE INTERESTS OF ADVANCED CABLE TIES, INC. | | | | | | | | | | | |